

ZCC2600



ZOOMLION

Zoomlion Heavy Industry Science & Technology Co.,Ltd.

Add: No.677, Lugu Road, Zoomlion Industrial Park, Changsha, Hunan, China, 410205

Copyright©2017 Zoomlion. All rights reserved. Reproduction and copying of any part of contents is not allowed for any purposes without Zoomlion's approval.



website.en.zoomlion.com

ZOOMLION

4.0
PRODUCTS

Vision Creates Future

ZOOMLION

CONTENTS

ZCC2600	Technical Highlights	01 - 02
ZCC2600	Dimensions	03
ZCC2600	Transport dimensions and weights	04 - 07
ZCC2600	Boom combination	08
ZCC2600	Technical description	09
ZCC2600	Self assembly system	10
ZCC2600	Erecting of boom to working position	11
ZCC2600	Lifting performance	12 - 24





EFFICIENT, QUICK AND SAFETY

- The mechanism operating speed up 20%, and the speed of each mechanism don't slow down while operating 2 functions simultaneously;
- Time of erecting the whole crane is less than 6 hours;
- Omni-directional real-time LMI and monitoring system, to ensure safety operation.

CONVENIENT, COMFORTABLE AND INTELLIGENCE

- The max. Single transport weight is 30.5t, transport width is 3m;
- Omni-directional vehicle information platform, real time monitoring equipment operation, The IOT intelligent interaction system make the mobile service come true.
- Full view cabin, buttons and switches are all within reach, all-around air conditioner form a comfortable operating space.



DIMENSIONS

Basic machine with undercarriage

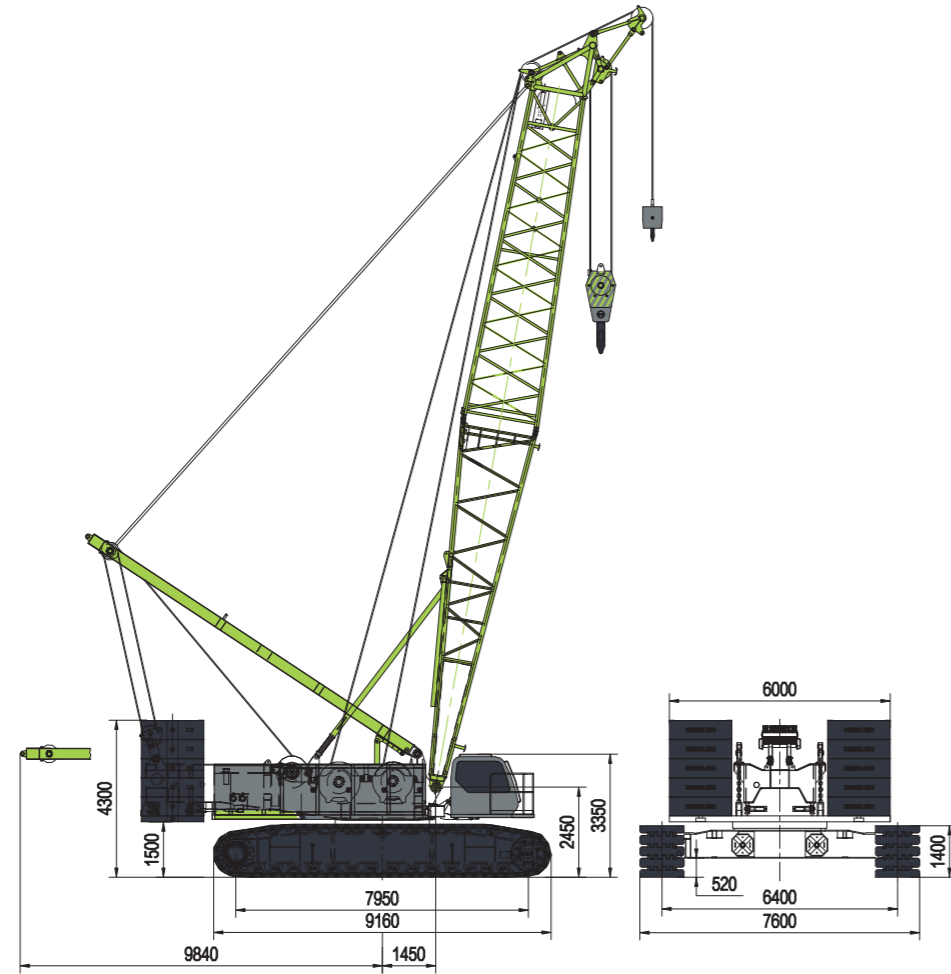

Operating weight

The operating weight includes the basic machine with crawlers, 2 main winches including wire ropes (300m and 480m) and 20m main boom, consisting of A-frame, boom foot (10m), boom head (10m), 83.7t basic counterweight, 32t carbody counterweight, and 260t hook block.

Total weight-----approx. 220t

Equipment

Main boom max. length-----83m
 High reach-----95m
 Luffing jib max. length-----60m
 Max. combination-----main boom 62m
 -----luffing jib 60m
 Fixed jib-----12-30m
 Auxiliary jib 25t

TRANSPORT DIMENSIONS AND WEIGHTS

Basic machine and main boom

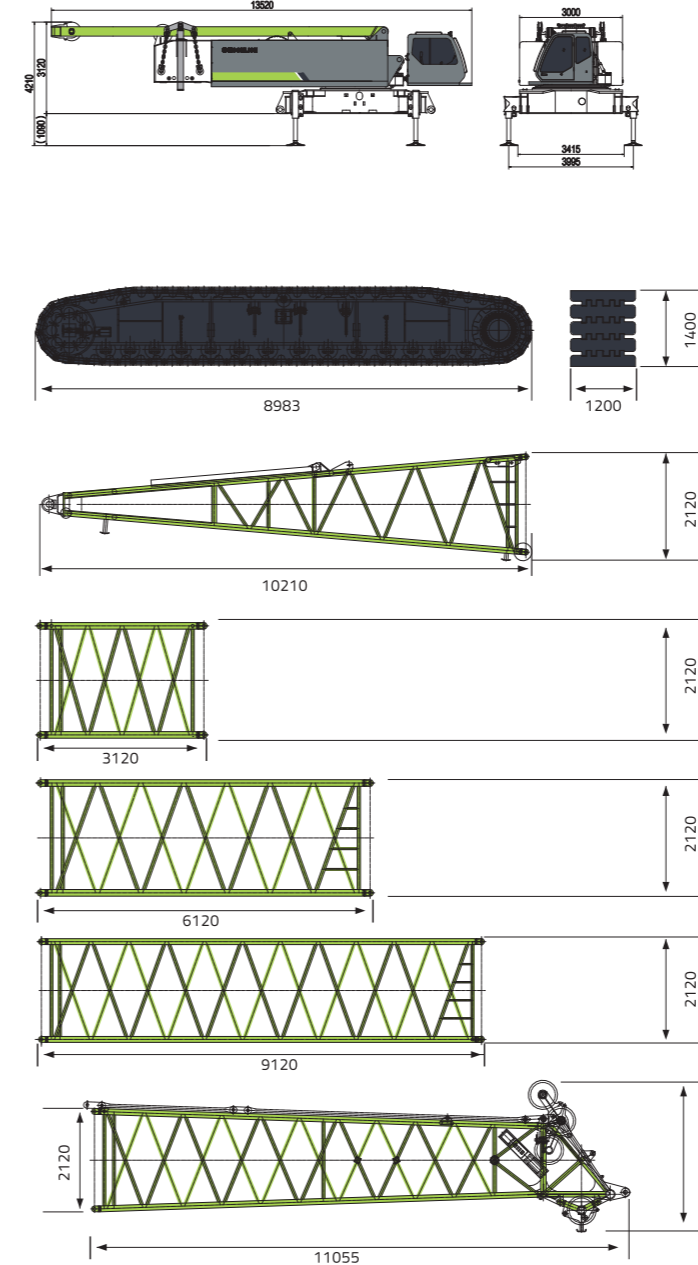

Basic machine

Width	3000mm
Weight A (Without hoisting winch, main boom tilting-back support, A-frame and main boom derricking winch)	32000kg
Weight B (Without hoisting winch and main boom tilting-back support)	37500kg
Weight C (Including hoisting winch, main boom tilting-back support, A-frame and main boom derricking winch)	45500kg

Crawler

	2x
Track pads	1200mm
Width	1200mm
Weight	24500kg

Boom foot

	1x
Width	2365mm
Weight	3300kg

3m boom section

	1x
Width	2320mm
Weight	850kg

6m boom section

	1x
Width	2320mm
Weight	1400kg

9m boom section

	6x
Width	2320mm
Weight	2000kg

Boom head

	1x
Width	2320mm
Weight	3500kg

TRANSPORT DIMENSIONS AND WEIGHTS

Luffing jib

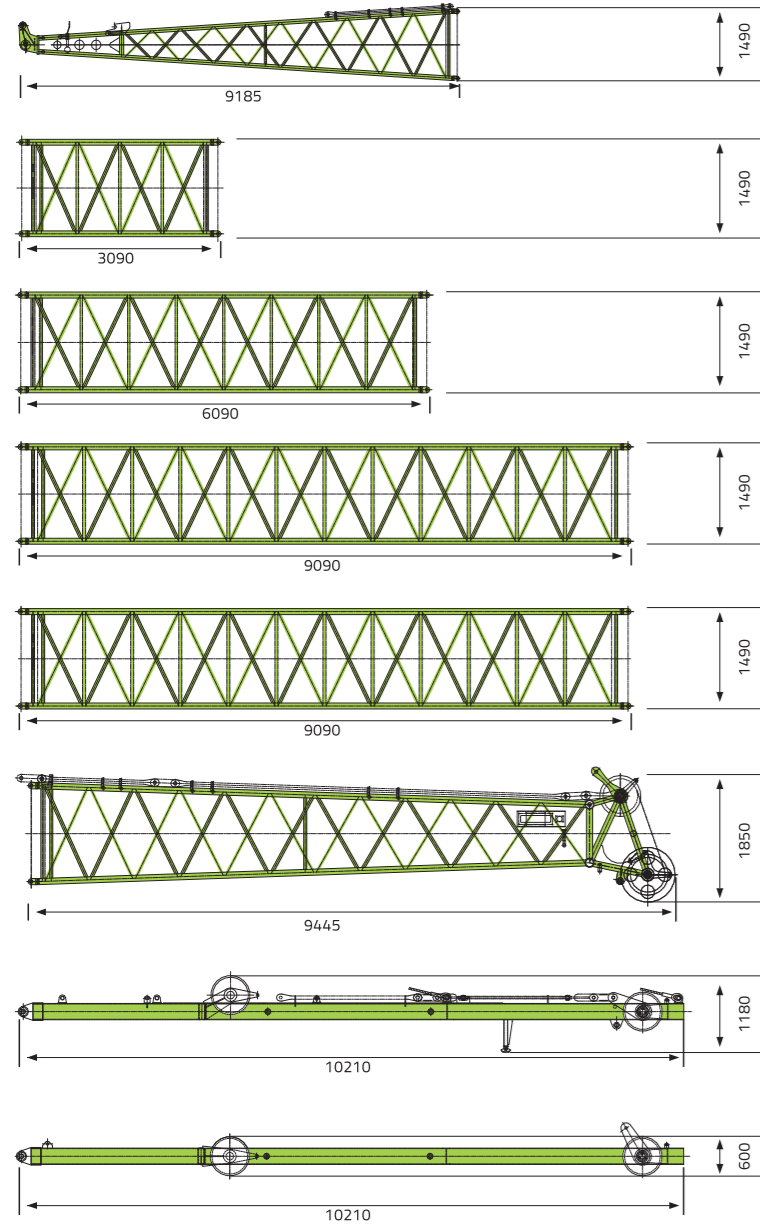

Luffing jib foot	1x
Width	1690mm
Weight	1100kg

3m luffing jib section	1x
Width	1690mm
Weight	370kg

6m luffing jib section	2x
Width	1690mm
Weight	660t

9m luffing jib section	1x
Width	1690mm
Weight	970kg

9m luffing jib section B	2x
Width	1690mm
Weight	830kg

Luffing jib head	1x
Width	1690mm
Weight	1100kg

WA-frame 2	1x
Width	1750mm
Weight	1750kg
WA-frame 1 (width: 1385 mm) – 1.63 t × 1	

WA-frame 1	1x
Width	1385mm
Weight	1630kg

TRANSPORT DIMENSIONS AND WEIGHTS

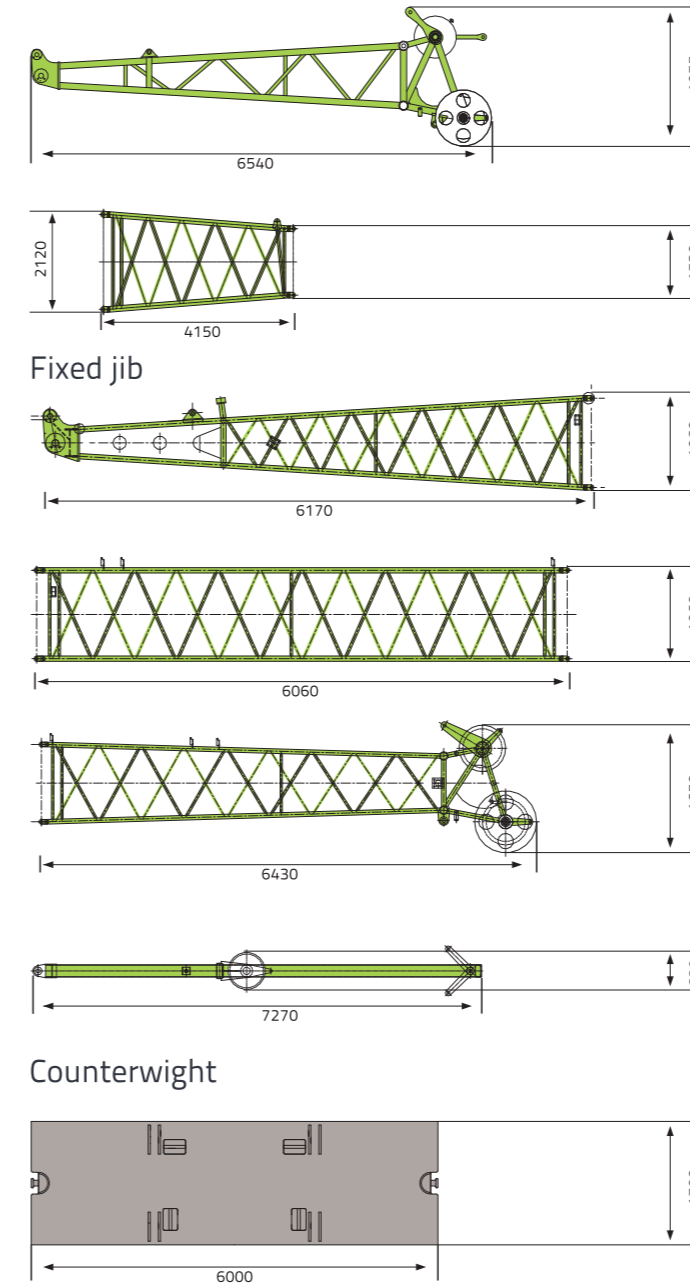

Heavy-duty fixed jib	1x
Width	1565mm
Weight	1000kg

4m L-boom section tapered	1x
Width	2320mm
Weight	1100kg

Fixed jib head	1x
Width	1540mm
Weight	500 kg

6m fixed jib section	3x
Width	1270mm
Weight	360 kg

Fixed jib head	1x
Width	1270mm
Weight	640kg
FA-frame (width: 1500 mm) – 0.75 t × 1	

FA-frame	1x
Width	1500mm
Weight	750kg

Counterweight base plate	1x
Thickness	160mm
Weight	12700kg
Counterweight plate (thickness: 510 mm) – 7.1 t × 10	

TRANSPORT DIMENSIONS AND WEIGHTS

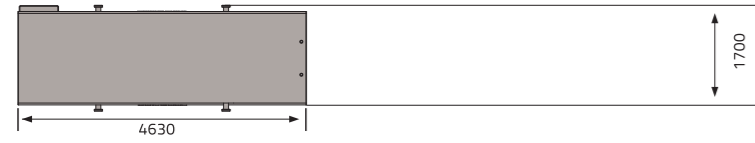
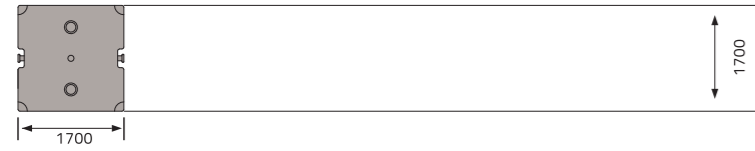
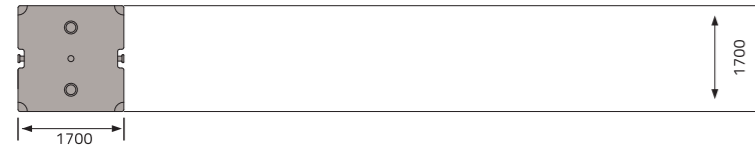

Hooks

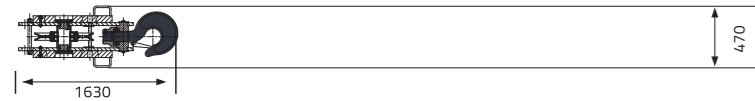
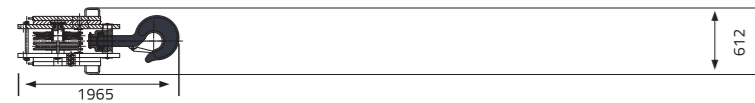
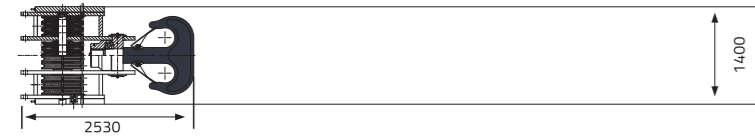

Counterweight	10x
Thickness	510mm
Weight	710kg
Counterweight plate (thickness: 300 mm, TBM operating mode for options) – 4.0 t × 2	

Counterweight for TBM operating mode	2x
Thickness	300mm
Weight	4000kg
Central counterweight (thickness: 650 mm) – 16 t × 2	

Carbody counterweight	2x
Thickness	650mm
Weight	16000kg

260t hook blocks-10 sheaves	1x
Weight	4230kg

160 t / 100 t hook blocks-6 sheaves	1x
Weight	2780kg

50t hook blocks-2 sheaves	1x
Weight	1700kg
30 t load hook – 1.08 t × 1	

30t hook blocks-1sheave	1x
Weight	1080kg

16t single hook	1x
Weight	530kg

BOOM COMBINATION

Descriptions fo Boom Assembly Codes		
Code	Type	Operation mode parameters
S	Heavy duty boom	20-83m
SL	Light dusy boom	86-95m
SW	Luffing jib	Main boom:23-62m jib:21-60m

Descriptions fo Boom Assembly Codes		
Code	Type	Operation mode parameters
SF	Fixed jib	Main boom:29-77m jib:12-30m
SFV	Heavy fixed jib	Main boom:41-77m jib:6m



TECHNICAL DESCRIPTION



Engine

Engine type—US Cummins QSL9-C305
 Rated power —227 kw/2000 rpm
 Maximum output torque —1505 Nm/1400 rpm
 Fuel tank h— 700 L
 Exhaust emission complies with U.S. EPA Tier 3 and EU Stage III A Emission Standards.



Hydraulic system

The hydraulic system is composed of main pump, control valve, hydraulic motor, hydraulic oil tank, oil cooler and so on. World-class pump-control system and load sensing control system are applied in the hydraulic system. The main hydraulic elements are imported, which have the advantages of high efficiency, energy-saving, great reliability and long service life.
 Oil cooler for hydraulic system: aluminium cooler, with the cooling fan driven by a motor
 Working pressure—350bar
 Hydraulic oil tank capacity— 700 L



Hoisting winch

The crane is fitted with two hoisting winches: hoisting winch 1 and hoisting winch 2. Both of them are composed of built-in axial piston variable displacement motor, balance valve, reducer, normally closed brake as well as wire rope. They are controllable independently. The hoisting rope is imported rotation-resistant wire rope. The hoisting winches have infinitely variable speed, which greatly improves the working efficiency.

Main winch

Line pull-----max.150KN
 Rope diameter-----28mm
 Drum diameter-----650mm
 Rope speed-----0-130m/min
 Rope length-----480m

Aux.winch

Line pull-----max.136KN
 Rope diameter-----28mm
 Drum diameter-----650mm
 Rope speed-----0-120m/min
 Rope length-----300m



Boom winches

The derricking rope is imported non rotation resistant wire rope.
 Line pull-----max. 102KN
 Rope diameter-----24mm x2
 Drum diameter-----540mm x2
 Rope speed-----0-80m/min
 Rope length-----440m x2



Crawler

The dual variable displacement motor and dual reducer are outfitted on the travel gear. The hydraulic motor, traveling reducer and traveling brake valve are all imported. Hydraulic chain tensioning device.
 Track pads-----1200mm
 Drive speed-----0-1.0km/h



Swing

The slewing mechanism consists of built-in axial piston dual variable displacement motor, dual gear reducer, normally closed slewing brake and pinion gear as well as slewing ring. The superstructure can realize 360° continuous rotation via slewing ring which is driven by the pinion gear. The application of closed hydraulic system and controllable free swing function can reduce the impacts on the crane and ensure that the slewing movements are initiated and stopped more stably.
 Swing speed-----0-1.2r/min

SELF ASSEMBLY SYSTEM

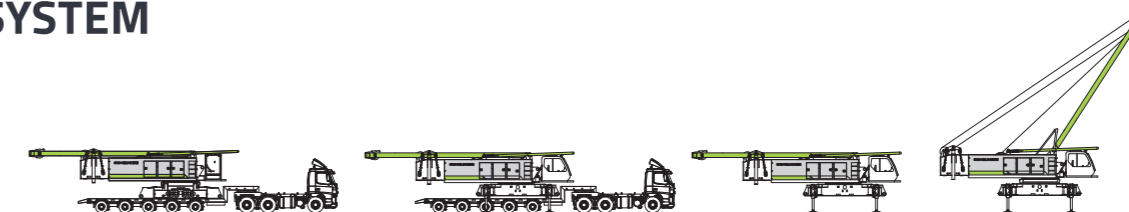

Unloading of basic machine

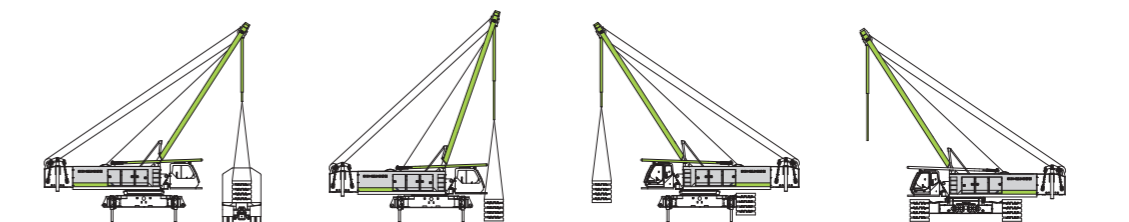

Unloading and assembly of crawler carrier

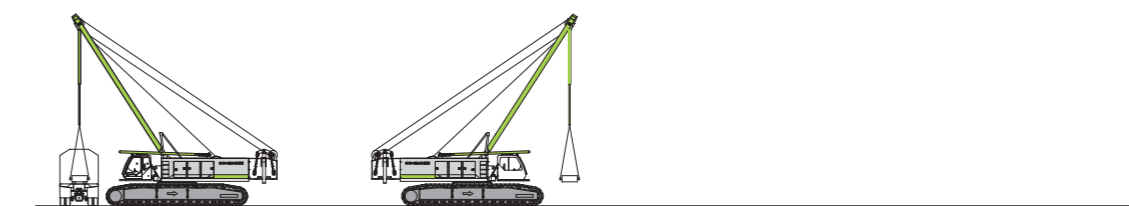

Unloading and assembly of central counterweight

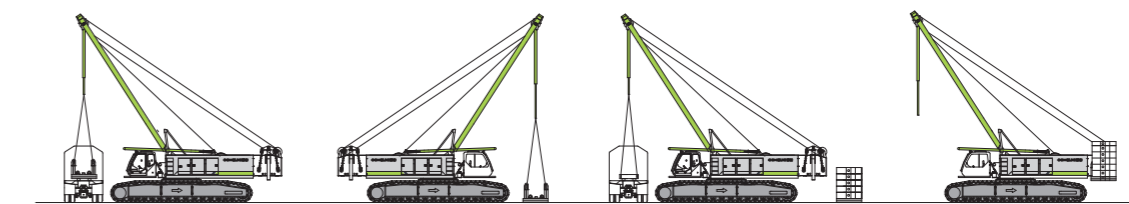

Unloading and assembly of rear counterweight

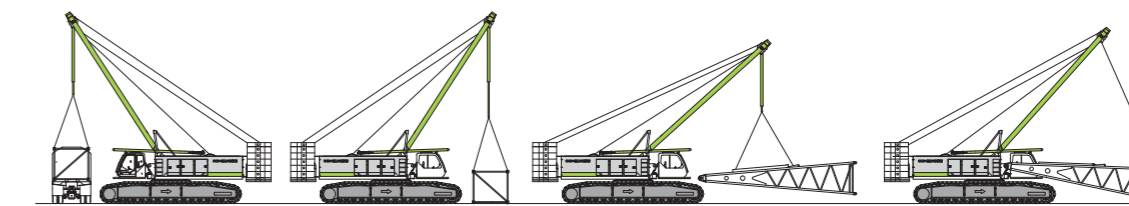

Unloading and assembly of frame

ERECTING OF BOOM TO WORKING POSITION

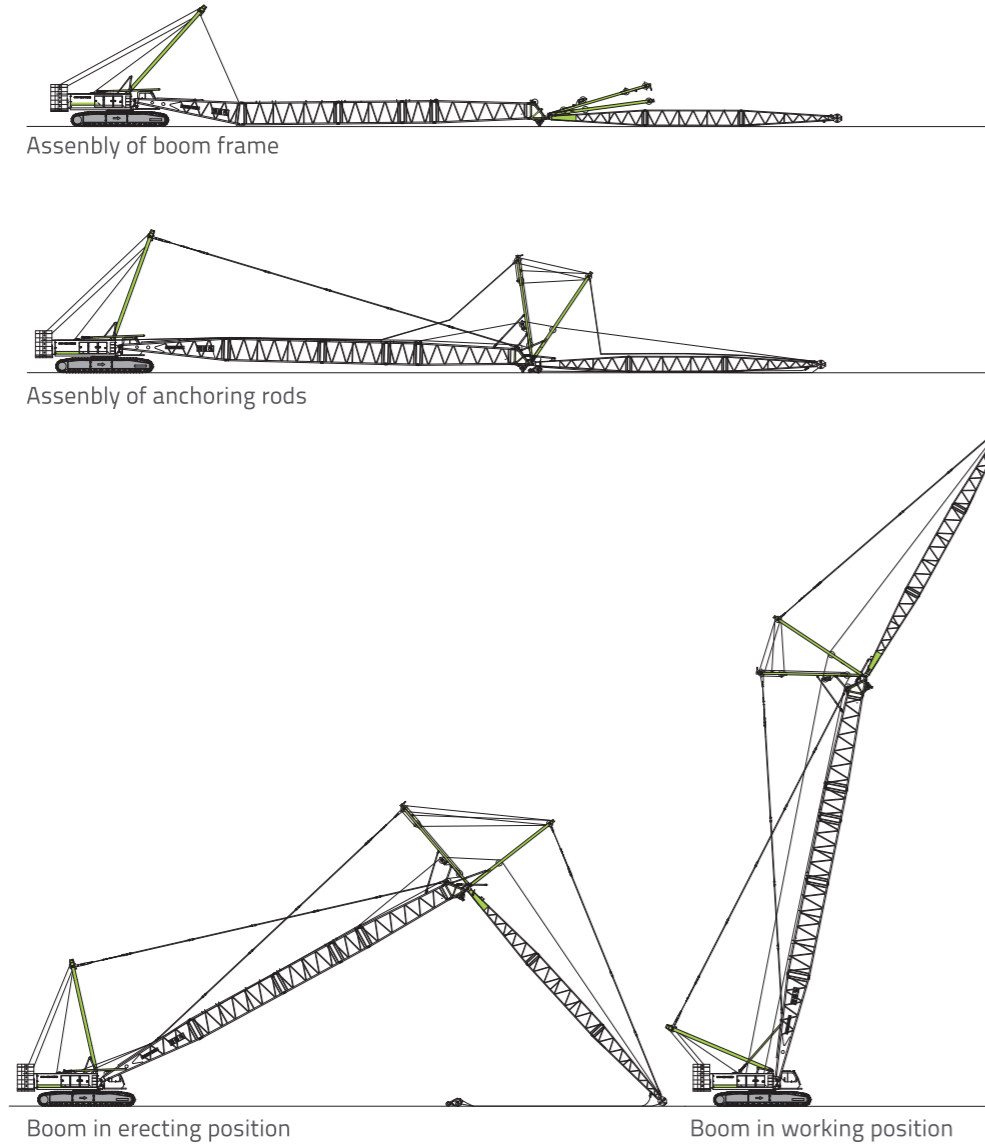

LIFTING PERFORMANCE

Lifting performance on S/SL boom

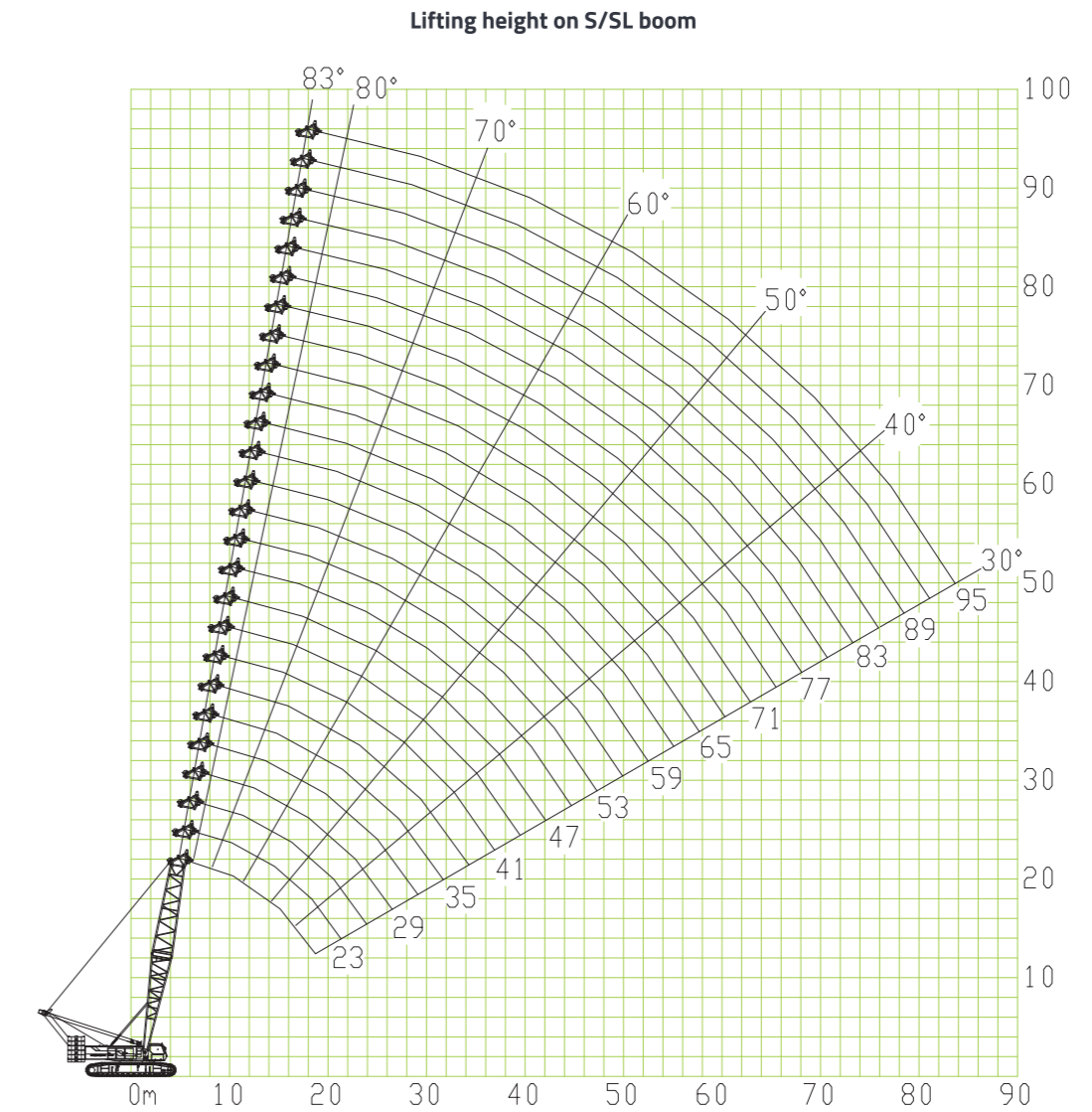

LIFTING PERFORMANCE

S-boom length (m)	Lifting capacity on S boom										
	20	23	26	29	32	35	38	41	44	47	50
Radius											
5	260										
6	227	200.8	193.1	184							
7	190.7	190.5	189	174	163	161					
8	175	166.6	164.5	162.5	158.4	149	149	135	118		
9	134.6	134.5	134.5	134.3	134.3	134.2	134.1	124	112	112	
10	132	130	128	125.9	123.9	121.9	121.9	119.8	110	110	102
12	102.9	102.7	102.5	102.2	102	101.6	99.5	97.5	97.5	95.5	93.4
14	83	83	82.8	82.6	82.5	82.2	82.1	82	81.3	81.3	79.2
16	69.1	69	68.8	68.7	68.7	68.5	68.5	68.4	68.4	68.3	68.3
18	59.1	59	58.9	58.7	58.6	58.6	58.6	58.6	58.6	58.6	58.5
20		51.5	51.4	51.4	51.4	51.4	51.4	51.2	51.1	51	50.8
22			45.6	45.6	45.5	45.5	45.4	45.3	45.1	45	44.8
24			40.7	40.7	40.7	40.6	40.4	40.3	40.2	40.1	39.9
26				36.6	36.6	36.6	36.5	36.4	36.2	36.1	35.9
28					33.2	33.2	33.1	32.9	32.8	32.7	32.6
30						30.3	30.3	30.2	30	29.9	29.6
32							27.9	27.7	27.6	27.5	27.4
34								25.6	25.5	25.3	25.2
36									23.5	23.4	23
38										21.7	21.4
40											21.1
42											18.3
44											16.7

S-boom length (m)	Lifting capacity on S boom												
	53	56	59	62	65	68	71	74	77	80	83		
Radius													
10	98	86											
12	93.4	85	83	80	70	68	60.9	55.4	50.3				
14	79.2	77.2	77.2	70	69	66.5	59.2	53.8	49	43.2	39.4		
16	67	67	67	65	65	64	57.4	52.2	47.4	41.9	38		
18	58.3	58.2	58	57.2	56.6	55.9	54.8	50.4	44.7	40.6	36.8		
20	50.7	50.5	50.3	50.2	49.4	48.9	48.4	47.7	43.4	39.4	35.8		
22	44.6	44.5	44.4	44.1	43.8	43.3	42.7	42.1	41.5	38.1	34.5		
24	39.8	39.5	39.4	39.3	39.1	38.5	38	37.4	37	36.5	33.4		
26	35.7	35.6	35.4	35.2	34.8	34.5	34.2	33.6	33.2	32.6	32.1		
28	32.4	32.2	31.8	31.5	31.2	30.8	30.5	30.1	29.7	29.3	28.9		
30	29.5	29.2	28.8	28.4	28.1	27.8	27.3	27	26.7	26.3	25.9		
32	26.5	26.5	26.1	25.8	25.3	25	24.6	24.4	23.9	23.6	23.3		
34	24.5	24.2	23.8	23.5	23	22.7	22.4	21.9	21.6	21.3	21		
36	22.5	22.1	21.7	21.4	21.1	20.6	20.3	20	19.6	19.2	18.9		
38	20.5	20.3	20	19.5	19.2	18.9	18.5	18.1	17.8	17.4	17.1		
40	19	18.7	18.3	18	17.7	17.2	16.9	16.6	16.1	15.8	15.5		
42	17.6	17.2	16.9	16.6	16.1	15.8	15.5	15	14.7	14.4	14		
44	16.3	15.9	15.6	15.2	14.8	14.5	14.1	13.8	13.4	13.1	13		
46	15.1	14.8	14.4	14	13.7	13.3	12.9	12.6	12.4	12.2	12		
48		13.7	13.4	12.9	12.6	12.3	11.8	11.7	11.5	11.3	11		
50			12.7	12.4	11.9	11.6	11.3	11	10.9	10.7	10.5		
52				11.4	11.1	10.7	10.3	10.3	10.1	9.9	9.7	9.3	
54					10.2	9.9	9.5	9.1	9.4	9.2	8.9	8.5	
56						9.1	8.9	8.8	8.7	8.5	8.2	8.2	
58							8.4	8	8.3	8.1	7.9	7.6	
60								7.4	7.7	7.5	7.3	7	
62									7.2	7	6.8	6.5	
64										6.5	6.3	6	
66											5.7	5.8	
68												5.1	
70													
72													

NOTE:
When tip boom is used, the lifting capacity on tip boom is the same as that on heavy duty boom at the same radius, but its max. lifting capacity should not exceed 25 t.

LIFTING PERFORMANCE

SL-boom length (m)	Lifting capacity on SL boom			
	86	89	92	95
Radius				
16	30.9/16.3	28.1/16.9	25.3/17.4	
18	30	27.3	24.9	21
20	29.9	25.9	24	20.4
22	27.9	24.6	22.8	19.7
24	27	23.9	21.7	19
26	26.1	23	20.6	18
28	25.2	22	19.8	17
30	23.1	21	19.2	16
32	21.2	20.3	18.3	15.8
34	19.4	18.6	17.7	14.4
36	17.8	17.1	16.5	13
38	16.3	15.7	15.7	11.9
40	14.9	14.6	14.5	10.8
42	13.8	13.5	13.4	9.8
44	12.7	12.4	12.3	9
46	11.7	11.5	11.4	8.2
48	10.8	10.5	10.4	7.4
50	9.9	9.6	9.5	6.7
52	9.1	8.8	8.7	6
54	8.4	8.1	8	5.3
56	7.7	7.4	7.3	4.8
58	7.1	6.7	6.6	4.3
60	6.5	6.1	6	3.8
62	5.9	5.6	5.5	3.3
64	5.4	5.1	5	2.9
66	5	4.6	4.5	2.7
68	4.5	4	3.9	2.6
70	4.1	3.4	2.8	2.5
72	3.7	2.8	2.7	2.4
74	3.4	2.7	2.6	2.3
76		2.6	2.5	2.3
78		2.5	2.4	2.2
80			2.2	2.1
82				2

Lifting performance on SF boom

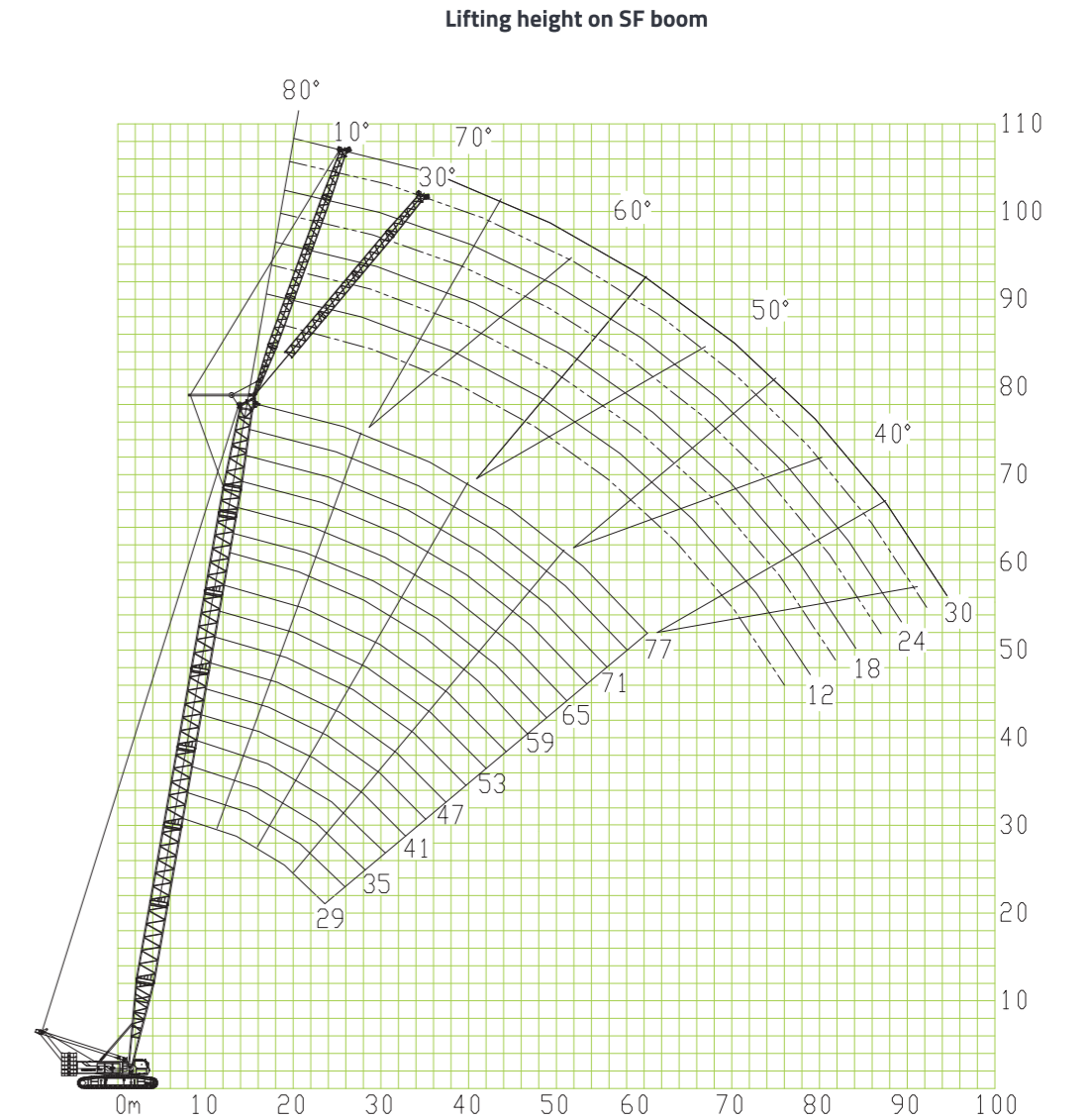

LIFTING PERFORMANCE

F-jib angle (°)	10.0	30.0	10.0	30.0	10.0	30.0	10.0	30.0
S-boom length (m)	29.0							
F-jib length (m)	12.0		18.0		24.0		30.0	
Radius								
10	34/10.5							
12	33.0							
14	32.5		27.0					
16	32.0	28.8	26.8		18.2			
18	31.3	26.8	25.7	20.5	18.1		13.0	
20	30.7	25.6	24.9	20.1	17.8		12.9	
22	30.0	24.5	24.2	19.1	17.3	14.1	12.6	
24	29.0	23.4	23.4	18.3	16.9	14.0	12.5	
26	28.0	22.4	22.8	17.5	16.6	13.9	12.3	10.0
28	27.0	21.6	22.1	16.8	16.2	13.6	12.0	9.9
30	25.5	20.9	21.2	16.2	15.9	13.0	11.7	9.8
32	24.0	20.2	20.7	15.6	15.5	12.5	11.5	9.6
34	22.6	19.6	20.0	15.0	15.2	12.0	11.2	9.4
36	21.7	19.2	18.9	14.6	14.9	11.6	10.9	9.2
38		18.8	18.0	14.1	14.7	11.1	10.6	9.0
40			17.1	13.6	14.1	10.8	10.4	8.7
42			16.1	13.2	13.8	10.5	10.2	8.4
44				12.9	13.5	10.1	10.0	8.2
46					13.0	9.8	9.8	8.0
48					12.2	9.6	9.5	7.8
50						9.0	9.4	7.5
52							9.2	7.4
54							9.1	7.2
56								7.2

F-jib angle (°)	10.0	30.0	10.0	30.0	10.0	30.0	10.0	30.0
S-boom length (m)	38.0							
F-jib length (m)	12.0		18.0		24.0		30.0	
Radius								
14	32.5							
16	32.0	28.5	26.0					
18	31.3	28.1	24.9		17.8			
20	30.7	26.9	24.2	19.8	17.5		12.8	
22	30.0	25.9	23.5	19.5	17.1		12.5	
24	29.0	24.8	22.7	19.2	16.6	14.0	12.3	
26	28.0	23.9	22.2	18.4	16.3	13.9	12.0	
28	27.0	23.0	21.4	17.7	15.9	13.7	11.7	9.7
30	25.5	22.2	20.6	17.1	15.6	13.5	11.3	9.6
32	24.0	21.5	20.1	16.5	15.3	13.2	11.1	9.4
34	22.6	20.8	19.4	15.9	14.9	12.7	10.8	9.3
36	21.7	20.3	18.3	15.4	14.6	12.3	10.6	9.1
38	20.9	19.5	17.5	14.9	14.4	11.8	10.3	8.9
40	19.4	18.6	16.6	14.3	13.9	11.4	10.1	8.8
42	18.3	17.4	15.7	13.7	13.6	11.1	9.9	8.6
44	17.1	16.5	14.9	12.8	13.3	10.7	9.7	8.6
46		15.7	14.4	12.1	12.8	10.4	9.5	8.3
48			13.9	11.6	12.0	10.1	9.3	8.1
50			13.4	10.8	11.3	9.8	9.2	7.9
52				10.3	10.7	9.5	8.9	7.7
54					10.1	9.2	8.8	7.5
56					9.6	9.1	8.6	7.4
58						8.7	8.3	7.2
60							8.2	7.1
62							8.0	7.0
64								7.0

LIFTING PERFORMANCE

F-jib angle (°)	10.0	30.0	10.0	30.0	10.0	30.0	10.0	30.0
S-boom length (m)	47.0							
F-jib length (m)	12.0		18.0		24.0		30.0	
Radius								
14	32.5							
16	32.0		25.2					
18	31.3	27.5	24.2		17.3			
20	30.7	27.1	23.5		17.0		12.4	
22	30.0	26.9	22.8	19.2	16.6		12.1	
24	29.0	26.0	22.0	18.9	16.2		11.9	
26	28.0	25.0	21.5	18.7	15.9	13.7	11.6	
28	27.0	24.2	20.8	18.3	15.5	13.5	11.3	
30	25.5	23.1	20.0	17.9	15.2	13.3	11.0	9.3
32	24.0	22.2	19.5	17.3	14.8	13.1	10.8	9.1
34	22.3	21.3	18.8	16.8	14.5	12.8	10.5	9.0
36	21.4	20.5	17.8	16.2	14.2	12.5	10.3	8.8
38	20.5	19.1	17.0	15.7	14.0	12.0	10.0	8.7
40	19.1	18.2	16.1	15.2	13.5	11.7	9.8	8.6
42	17.8	17.1	15.2	14.2	13.2	11.5	9.6	8.4
44	16.6	16.2	14.5	13.3	12.9	11.0	9.4	8.4
46	15.4	15.4	14.0	12.4	12.4	10.6	9.2	8.2
48	14.4	14.6	13.5	11.7	11.6	10.2	9.0	8.1
50	13.5	13.7	13.0	11.3	11.0	9.8	8.9	7.9
52	12.6	12.8	12.5	10.5	10.4	9.5	8.7	7.8
54		12.0	12.0	10.0	9.8	9.1	8.6	7.7
56			11.6	9.2	9.3	9.0	8.3	7.6
58			10.8	9.0	8.8	8.6	8.1	7.5
60				8.0	8.4	8.3	8.0	7.4
62					8.0	8.0	7.8	7.2
64					7.5	7.5	7.5	7.1
66						7.0	7.3	7.0
68							7.0	6.9
70							6.8	6.4
72								5.6

F-jib angle (°)	10.0	30.0	10.0	30.0	10.0	30.0	10.0	30.0
S-boom length (m)	56.0							
F-jib length (m)	12.0		18.0		24.0		30.0	
Radius								
16	32.0							
18	31.5		25.1					
20	30.9	27.0	24.2		16.8			
22	30.4	26.6	23.4		16.6		12.1	
24	28.3	26.5	22.7	18.9	16.4		12	
26	27.0	26.0	22.0	18.7	16.1		11.8	
28	26.3	23.5	21.4	18.6	15.8	13.5	11.5	
30	25.6	21.4	20.8	18.3	15.5	13.4	11.3	
32	24.8	19.5	20.2	18.1	15.2	13.2	11	9.2
34	23.5	18.6	19.7	17.8	15	13.1	10.8	9.1
36	21.6	18.1	19.2	17.1	14.7	12.9	10.5	8.9
38	19.9	17.6	18.7	15.8	14.4	12.8	10.3	8.8
40	18.4	17.2	17.9	14.7	14.2	12.6	10.2	8.6
42	17	16.8	17.0	13.7	13.5	12.4	9.9	8.6
44	15.8	16.2	16.2	12.7	12.6	12.1	9.7	8.4
46	14.7	15.1	15.1	12.5	11.8	11.9	9.5	8.3
48	13.7	14.0	14	12.1	11.1	11.4	9.3	8.3
50	12.7	13.0	13.1	11.9	10.4	10.8	9.2	8.1
52	11.9	12.1	12.2	11.6	9.8	10.2	9	8
54	11.1	11.3	11.4	11.4	9.2	9.6	8.9	7.8
56	10.4	10.6	10.7	11.1	9.0	9.0	8.7	7.7
58	9.7	9.9	10	10.4	8.8	8.6	8.4	7.7
60	9.1	9.2	9.4	9.7	8.6	8.0	8	7.5
62			8.8	9.1	8.5	7.6	7.5	7.4
64			8.3	8.5	8.3	7.3	7.1	7.4
66			7.7	7.9	8	7.2	6.8	7.1
68					7.5	7.1	6.5	6.7
70					7	7.0	6	6.4
72					6.6	6.5	5.5	6
74							5	5.6
76							4.4	5
78							3.6	4.4

LIFTING PERFORMANCE

F-jib angle (°)	10.0	30.0	10.0	30.0	10.0	30.0	10.0	30.0
S-boom length (m)	71.0							
F-jib length (m)	12.0		18.0		24.0		30.0	
Radius								
18	32.0							
20	31.8		25.3					
22	30.4	27.0	24.5		17.7			
24	27.5	26.5	23.8		17.1			
26	27.0	25.3	23.2	18.9	16.7		12.1	
28	26.3	22.9	22.5	18.7	16.1		12	
30	25.8	21.1	21.8	18.6	15.6	13.5	11.7	
32	24.5	20.5	21.0	18.5	15.3	13.4	11.5	
34	22.3	19.9	19.8	17.9	15.5	13.3	11.3	9.2
36	20.4	19.4	19.2	16.5	16.2	13.2	11.1	9.1
38	18.7	19.0	18.8	15.2	16.5	13.1	10.8	9
40	17.2	17.8	17.6	14.4	16.2	12.9	10.7	8.9
42	15.8	16.4	16.2	14.0	16	12.9	10.5	8.8
44	14.6	15.1	15	13.7	15.3	12.6	10.3	8.6
46	13.4	14.0	13.8	13.4	14.2	11.7	10.1	8.6
48	12.4	12.9	12.8	13.1	13.1	10.9	9.9	8.5
50	11.5	11.9	11.9	12.6	12.2	10.2	9.8	8.4
52	10.6	11.0	11	11.7	11.3	9.5	9.2	8.3
54	9.8	10.2	10.2	10.8	10.5	8.9	8.6	8.3
56	9.1	9.5	9.5	10.0	9.8	8.4	8.1	8.1
58	8.4	8.8	8.8	9.3	9.1	7.9	7.7	8
60	7.8	8.1	8.2	8.6	8.4	7.7	7.2	7.7
62	7.2	7.5	7.6	8.0	7.8	7.6	6.8	7.3
64	6.7	6.9	7	7.4	7.2	7.6	6.4	6.8
66	6.1	6.4	6.4	6.8	6.6	7.4	6	6.5
68	5.6	5.8	5.8	6.2	6	7.3	5.6	6.1
70	5	5.2	5.3	5.6	5.5	6.7	5.3	5.7
72	4.6	4.7	4.8	5.1	5	6.2	5	5.4
74	4.3	4.3	4.4	4.6	4.6	5.8	4.7	5.1
76			4.1	4.3	4.3	5.3	4.4	4.8
78			3.9	4.0	4	4.9	4.1	4.4
80				3.7	3.8	4.4	3.8	4.2
82					3.5	4.1	3.6	3.9
84					3.3	3.7	3.3	3.7
86						3.4		3.5
88								3.2

LIFTING PERFORMANCE

Lifting height on SW boom

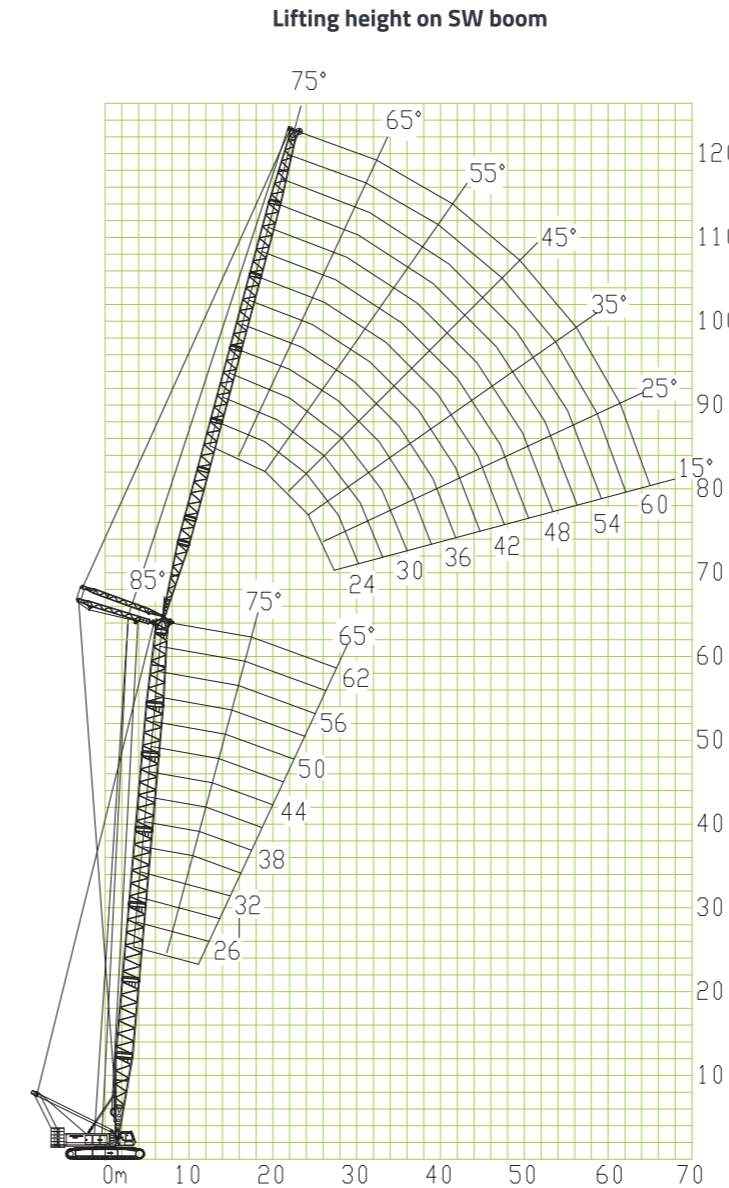

S-boom length(m)	29																	
W-jib length(m)	27			33			39			45			51			60		
S-boom angle	85°	75°	65°	85°	75°	65°	85°	75°	65°	85°	75°	65°	85°	75°	65°	85°	75°	65°
Radius(m)																		
14	68.1			57.3														
16	62.5			54			41.9											
18	57.2			50.3			40.8			31.2								
20	53.3			47			39.7			29.8			22.3					
22	48.8			43.9			38.3			29.1			21.7			12		
24	44.1	42.1		40.9			37			28.6			21.1			11.4		
26	40	38.4		37.9	38		35.4			27.5			20.5			11		
28	33.1	35.1		34.3	34.9		33.6	32.5		26.9			20.1			10.7		
30	25.6	32.3		31.4	32.1		30.8	32		26.3			19.6			10.3		
32		29.9	27.3	28.9	29.8		27.2	29.6		24.8	27		19.1	16.7		10		
34		27.9	25.3	25.6	27.7		25.1	26.9		22.8	26.4		18.6	16.5		9.7		
36		26	23.6	20.6	25.9	23	23.3	24.9		21.1	24.5		18.3	16.3		9.4		
38			22.1	24.3	21.5	21.7	23.3	19.6	19.6	22.8			17.2	15.8		9.1	9.8	
40			20.7	22.9	20.2	20	21.8	19.5	18.5	21.3			16	15.4		8.9	9.4	
42					18.9	16.3	20.4	18.4	17.4	20	17	15	15			8.6	9.2	
44					17.7	19.3	17.2	16.5	18.7	16.7	14.1	14.7				8.4	8.9	
46					16.8	18.2	16.3	15.9	17.7	15.8	12.1	14.2	14.5			8.1	8.6	
48							15.3	13.1	16.7	14.8	11.3	12.8	14.3			7.7	8.4	
50							14.5		15.7	14	10.8	12.3	13.4			7.4	8.2	8.6
52								15	13.2	10.2	11.7	12.7	6.9	7.9		8.4		
54										12.5	10	11.1	12.1	6.6	7.6	8.2		
56										11.9	10.6	11.3	6.3	7.1	7.9			
58										11.3	10.1	10.8	6.1	6.8	7.6			
60												10.3	5.7	6.5	7.2			
62													9.8	5.5	6.2	6.8		
64														9.2		5.9	6.5	
66																5.6	6	
68																	6	
70																		5.6

LIFTING PERFORMANCE

S-boom length(m)	41																																			
W-jib length(m)	27			33			39			45			51			60																				
S-boom angle	85°	75°	65°	85°	75°	65°	85°	75°	65°	85°	75°	65°	85°	75°	65°	85°	75°	65°																		
Radius(m)																																				
12																																				
14																																				
16	62.5			55.6																																
18	55.6			52.2			41.4			31.7																										
20	50			48.7			40.3			30.8			22.6																							
22	45.6			45			39			29.4			22																							
24	41.6			40.9			37.7			28.9			21.4			11.7																				
26	38.1			32.5			37.5			36.4			27.8			20.8			11.2																	
28	35.3			32.2			34.7			29.2			34.1			27.2			20.3			10.9														
30	30.9			29.7			32.2			29			31.6			26.6			19.8			10.6														
32				27.4			30			27.8			29.5			26.3			26			19.3			10.2											
34				25.5			27			25			26.3			24.5			23.7			23.1			18.9			9.8								
36				23.7			20.2			24.4			23.2			24.4			22.7			22			22.2			18.5			19.5			9.5		
38				22.3			20			21.7			22.7			21.2			20.4			20.7			17.9			19.3			9.2					
40				18.7			20.4			18.2			21.2			19.8			19			19.3			16.6			18.8			9			9.5		
42				17.6			19.1			18			19.6			18.7			18			18.2			15.5			17.6			8.8			9.3		
44				16.6			18.1			17			17.5			14.8			17			17.1			14.5			16.6			8.6			9		
46										16.1			16.6			14.6			16.1			16.1			12.5			15.6			8.4			8.8		
48							15.1			15.6			13.8			15.4			15.2			13.2			11.7			14.7			7.9			8.5		
50							14.3			14.8			13			14.4			12.5			11.1			13.9			11.5			7.6			8.3		
52							13.5						12.4			13.7			11.9			10.5			13.1			11.3			7.2			8.1		
54										11.8			12.9			11.2			10			12.5			10.7			6.8			7.9					
56										11.1						10.6			11.8			10.1			6.5			7.6			8.2					
58													10.1			11.2			9.6			6.2			7.1			8.1								
60													9.6			10.6			9.1			5.9			6.8			7.8								
62													9.1						8.6			5.6			6.5			7.4								
64																8.2						6.2			7											
66																7.8						5.9			6.7											
68																7.5						5.7			6.3											
70																			5.5			6														
72																									5.7											
74																												5.4								
76																															5.4					

S-boom length(m)	47																																			
W-jib length(m)	27			33			39			45			51			60																				
S-boom angle	85°	75°	65°	85°	75°	65°	85°	75°	65°	85°	75°	65°	85°	75°	65°	85°	75°	65°																		
Radius(m)																																				
14	58.8																																			
16	52.5			51.3																																
18	46.9			46.1			41.6																													
20	42.8			41.9			40.5			30																										
22	39.1			38.1			39.4			29.5			22.2																							
24	35.9			35			37.5			29.1			21.6			11.5																				
26	33.1			32.5			34.4			28.4			21			11.3																				
28	30.6			28.7			30.3			31.9			27.3			20.4			10.9																	
30				26.7			28.4			25.8			30			26.8			19.9			10.7														
32				24.7			26.6			24.2			27.8			23.6			26.2			19.5			10.3											
34				23			25			22.5			25.9			23.4			24.3			19			9.9											
36				21.5			21			24.4			21.9			22.7			21.2			18.6			9.6											
38				20.2			19.7			22.8			20.5			21.1			19.8			18.2			19.2			9.2								
40				16.6			18.5			21.4			19.2			19.7			18.7			16.9			18.1			9								
42				15.6			17.4			15			20			18.1			18.5			17.5			15.8			17			8.8			9.6		
44				14.7			17.2			14.2			16.9			17.4			16.5			14.7			16			8.6			9.2					
46				13.6			17			13.4			16			13			16.4			15.5			13.8			15			8.4			8.9		
48				12.9						12.7			15.1			12.8			15.6			14.6			12			14.2			8			8.7		
50							12.1			14.3			12.2			13.9			11.2			13.3			7.7			8.5								
52							11.7			14.1			11.6			13.1			10.9			10.7			12.6			7.3			8.3					
54							11						10.9			12.4			10.4			10.1			12			9.9			6.9			8.1		
56										10.4			11.8			9.9			11.3			9.3			6.6			7.9								
58										9.9			11.4			9.3			10.7			8.8			6.3			7.5			8					
60													8.8			10.2			8.3			5.9			7			7.1			7.1					
62													8.4			9.7			7.9			5.7			6.7			6.7								
64													8						7.5			5.5			6.4			6.4								
66													7.8						7.1			6.1			6											
68																			6.7			5.8			5.7											
70																			6.4			5.6			5.4											
72																						5.2			5											
74																									4.8											
76																									4.5											
78																									4.4											

LIFTING PERFORMANCE

S-boom length(m)	53																																			
W-jib length(m)	27			33			39			45			51			60																				
S-boom angle	85°	75°	65°	85°	75°	65°	85°	75°	65°	85°	75°	65°	85°	75°	65°	85°	75°	65°																		
Radius(m)																																				
14																																				
16	55																																			
18	49.1			48.1			41.9																													
20	44.4			43.4			40.8			31.3																										
22	40.3			39.4			38.8			29.8			22.1																							
24	36.9			35.9			35.3			29.2			21.7			12																				
26	33.8			33.1			32.5			28.6			21.1			11.4																				
28	31.3			30.6			30.3			27.5			20.6			11																				
30	29.4			27.8			28.8			28.1			26.9			20.1			10.7																	
32	27.2			25.9			26.6			25.1			26.3			25.6			19.6			10.3														
34				24.3			25			23.4			24.4			21.6			23.9			19.1			10											
36				22.7			23.4			22			22.8			21.2			22.5			20.5			18.7			9.7								
38				21.2			22			20.7			21.6			19.9			20.9			19.3			18.3			9.4								
40				19.9						19.4			20.3			18.8			19.8			18.1			17.3			17.3			9.1					
42				19.4			15.4			18.2			19.2			17.7			18.8			17			16.1			16.4			8.9					
44				14.6			17.1			18.1			16.6			17.8			16.1			15			15.4			8.7			9.7					
46				13.8			16.2			13.1			15.6			16.9			15.4			14.1			14.6			8.5			9.3					
48				13			16			12.4			14.8			13.2			15.9			14.2			12.2			13.8			8.1			9.1		
50				12.3						11.8			14			11.2			13.5			11.3			12.9			7.7			8.9					
52							11.1			13.3			10.6			12.7			10			10.8			12.3			7.4			8.7					
54							10.6						10			12.1			9.5			10.2			11.6			6.9			8.3					
56							10.1						9.5			11.4			8.9			11			8.6			6.6			8.1					
58										9			10.9			8.5			10.4			8			6.3			7.9								
60													8.6						8.1			10			7.5			6.1			7.5					
62																7.7			9.4			7.1			5.7			7.2			6					
64																7.2			9			6.7			5.5			6.7			5.6					
66																6.9						6.4			6.4			5.3								
68																6.5						6			6.1			4.9								
70																						5.7			5.9			4.6								
72																						5.5			5.7			4.4								
74																									4.1											
76																									3.9											
78																									3.7											
80																									3.5											

S-boom length(m)	59																				
W-jib length(m)	27			33			39			45			51			60					
S-boom angle	85°	75°	65°	85°	75°	65°	85°	75°	65°	85°	75°	65°	85°	75°	65°	85°	75°	65°			
Radius(m)																					
14																					
16	51.9																				
18	46.3			45.6																	
20	41.9			40.9			40														

LIFTING PERFORMANCE

S-boom length(m)	62																	
W-jib length(m)	27			33			39			45			51			60		
S-boom angle	85°	75°	65°	85°	75°	65°	85°	75°	65°	85°	75°	65°	85°	75°	65°	85°	75°	65°
Radius(m)																		
14																		
16	50.6																	
18	45			44.4														
20	40.6			39.7			38.8											
22	36.9			36			35.3				30.7				22.6			
24	33.8			32.8			32.2			29.4			21.9			14.8		
26	30.9			30.2			30			28.2			21.3			13.2		
28	28.8			28.1			27.5			26.5			20.7			12.7		
30	26.9			26.3			25.6			25			20.2			12.4		
32	25	26.8		24.4			23.8			23.4			19.8			12		
34		25		22.8	24.4		22.2			21.9			19.3			11.7		
36		23.1		21.4	22.5		20.9	22.2		20.3			18.8			11.3		
38		21.6		20.2	21.1		19.7	20.6		19.1	20.3		18.4			11		
40		20.3			20		18.4	19.5		17.9	19.2		17.5			10.7		
42		19.4			19.1		17.5	18.2		17	18.1		16.6	17.5		10.5		
44		18.4			18.1		16.6	17.1		16	16.9		15.6	16.4		10.3		
46			14.7		17.2			16		15.2	16		14.8	15.6		10	11.4	
48			14.3		16.3	13.2		15.2		14.6	15.3		13.9	15		9.6	11	
50			13.4		15.5	12.6		14.6		14.1	14.5		11.7	14.4		9.1	10.8	
52			12.8			12.1		14.2	11.5		13.8		11.1	13.8		8.6	10.5	
54			12.2			11.5		13.8	10.9		13.2		10.5	13.1		8.1	10.3	
56			11.8			10.9		13.1	10.3		12.6	10.3	10	12.5		7.7	10	
58						10.3			9.8		12.2	9.7		11.9		7.2	9.8	
60						9.8			9.5		11.9	9.4		11.3		6.8	9.4	
62									8.9			8.8	10.6	8.4	6.2	8.8		
64									8.6			8.4	10.3	7.8	6.2	8.4	6.9	
66												8.1	10	7.5		7.9	6.6	
68												7.8		7.2		7.5	6.3	
70												7.2		6.6		7.1	6	
72												6.9		6.3		6.7	5.7	
74														5.9		6.3	5.5	
76														5.8		6	5.2	
78														5.6			4.9	
80														5.3			4.6	
82																	4.5	
84																		4.3

LIFTING PERFORMANCE

Lifting performance on SFV boom

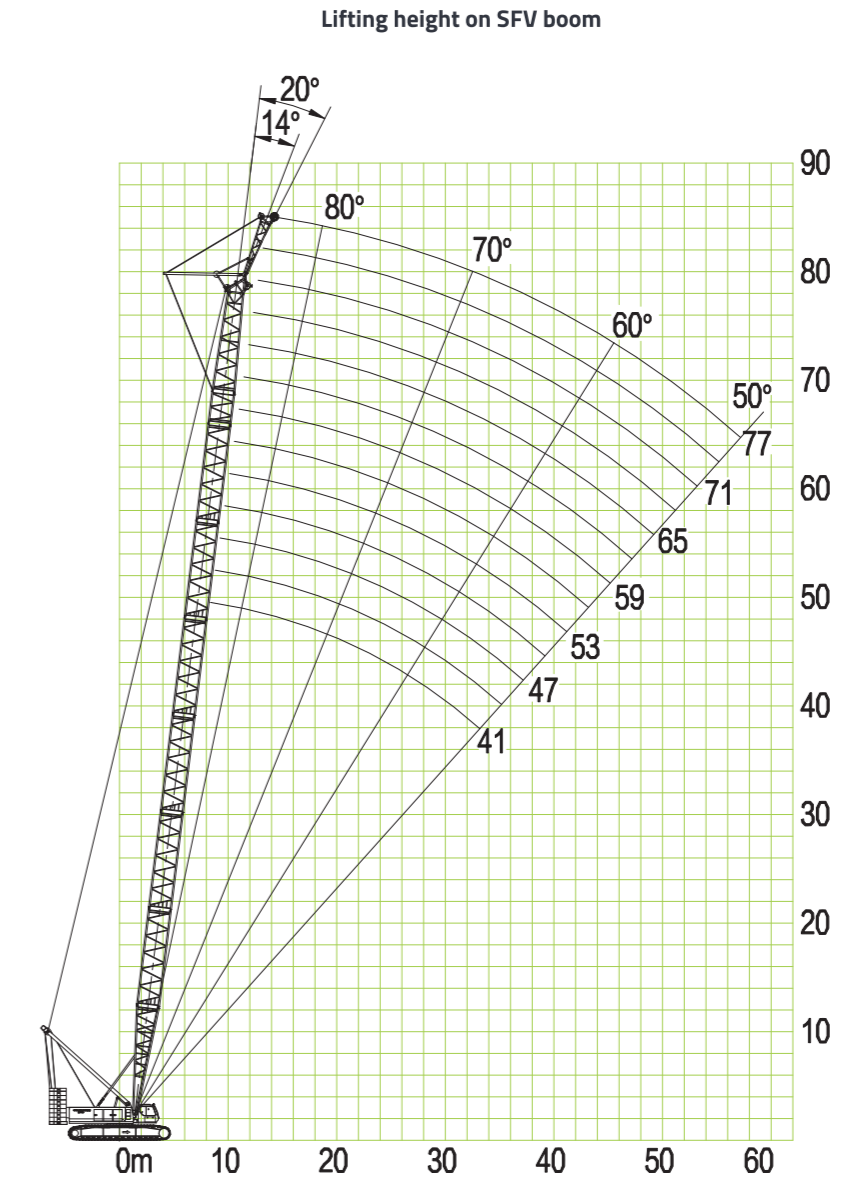

LIFTING PERFORMANCE

Radius (m)	S-boom length (m)							
	41		44		47		50	
	FV-jib angle (°)							
	14	20	14	20	14	20	14	20
10	60.0	56.9	60.0	56.9/11	60.0/11	56.9/11		
12	60.0	54.7	60.0	54.7	60.0	54.7	60.0/11	
14	60.0	50.3	60.0	52.5	60.0	52.5	60	56.9
16	58	48.1	59.1	48.1	60.0	50.3	60	52.5
18	54.7	45.9	56.9	45.9	56.9	48.1	60	50.3
20	51.4	43.8	52.4	43.8	51.9	45.9	58	48.1
22	47.2	41.6	46.7	42.7	46.1	43.8	51.2	45.9
24	42	39.4	41.9	41.6	41.5	41.6	45.6	43.8
26	37.8	37.8	37.7	37.7	37.4	37.5	40.9	41.1
28	34.1	34.2	34.1	34.1	33.8	34	37	37.1
30	31.1	31.1	31	31.1	30.8	30.8	33.6	33.7
32	28.5	28.5	28.4	28.4	28.1	28.2	30.6	30.6
34	27.3/33	27.3/33	26	26	25.8	25.9	27.8	28
36			25/35	25/35	23.9	23.9	25.5	25.6
38					22.9/37	22.9/37	23.6	23.6
40							21.7/39	21.8/39
42								

CAUTION:

- The lifting capacity is given in metric tons, and the sign '* / *' indicates 'lifting capacity / radius'. The values in grey are determined by boom strength, while the rest values are determined by crane stability.
- For SFV boom configuration, S-boom angle = 50° – 83°, FV-jib angle = 14° or 20°, and FV-jib length = 6 m.

LIFTING PERFORMANCE

Radius (m)	S-boom length (m)							
	53		56		59		62	
	FV-jib angle (°)							
	14	20	14	20	14	20	14	20
11	60.0							
12	60.0	56.9	60.0	56.9	60.0	56.9/13	60.0	56.9/13
14	60.0	54.7	60.0	54.7	60.0	54.7	60.0	55.8
16	60.0	51.4	60.0	52.5	59.1	52.5	56.9	52.5
18	57.4	49.2	56.9	50.3	55.8	50.3	53.6	50.3
20	51.2	47	50.3	48.1	49.2	48.1	48.1	49.2
22	45.6	44.8	44.8	44.8	43.8	43.8	43.2	43.8
24	40.9	41.1	40.4	40.5	39.9	40	39.4	39.4
26	37	37.1	36.6	36.7	36	36.1	35	35.5
28	33.4	33.4	33.2	33.3	32.7	32.8	31.7	32.3
30	30.3	30.4	30.1	30.1	29.5	29.9	29.5	29.5
32	27.7	27.7	27.4	27.5	27.1	27.3	27	27
34	25.4	25.4	25.1	25.2	24.8	25	24.7	24.7
36	23.3	23.4	23.2	23.2	22.8	22.9	22.6	22.6
38	21.5	21.5	21.3	21.4	21	21.1	20.8	20.8
40	19.9	19.9	19.8	19.8	19.5	19.5	19.2	19.2
42	19.2/41	19.2/41	18.3	18.3	18	18	17.7	17.8
44			17.6/43	17.6/43	16.6	16.7	16.5	16.5
46					16.1/45	16.1/45	15.2	15.2
48							14.7/47	14.7/47
50								

Radius (m)	S-boom length (m)							
	65		68		71		74	
	FV-jib angle (°)							
	14	20	14	20	14	20	14	20
13	55.2	54.1	49.2		44.6			
14	55	53.9	48.7	47.9	42.4	41.6	38	37.2
16	53.9	53	47.6	46.8	41.6	41	37.1	36.5
18	50.9	50.3	46.8	45.9	40.5	39.9	36.4	35.8
20	48.1	47.6	45.7	45.1	39.6	39.1	35.3	35
22	42.7	42.7	41.6	42.7	38.8	38.3	34.3	33.9
24	38.3	38.3	37.2	37.7	37.2	37.2	33.5	33.1
26	35	35	33.9	33.9	33.4	33.4	32.7	32.4
28	31.7	31.7	30.6	30.6	30.1	30.1	29.5	29.5
30	28.4	28.4	28.2	28.2	27.9	27.9	27.3	27.3
32	26.3	26.8	25.7	26.3	25.2	25.2	24.6	24.6
34	24.1	24.5	23.5	23.5	23	23	22.4	22.4
36	22.4	22.4	21.9	21.9	21.3	21.3	20.8	20.8
38	20.6	20.7	19.7	19.7	19.1	19.7	18.6	19.1
40	18.9	19.1	18	18.6	18	18	17.5	17.5
42	17.5	17.5	17	17	16.4	16.4	15.9	15.9
44	16.2	16.2	15.3	15.6	15.3	15.3	14.8	14.8
46	15	15	14.2	14.2	13.7	13.9	13.4	13.7
48	13.9	13.9	13.4	13.4	13.1	13.1	12.6	12.6
50		13.4/49	12.6	12.6	12	12	11.5	11.5
52				12/51	11.2	11.2	10.7	10.9
54						10.9/53	9.8	9.8
56								9.3/55
58								

Radius (m)	S-boom length (m)	
	77	
	FV-jib angle (°)	
	14	20
14	33.6	32.5/15
16	32.9	32.4
18	32.3	31.7
20	31.3	30.9
22	30.6	30.2
24	29.7	29.4
26	28.7	28.4
28	26.9	26.7
30	26.3	26
32	24.1	24.1
34	21.9	21.9
36	19.7	20.2
38	18	18.6
40	17	17
42	15.3	15.3
44	14.2	14.2
46	13.1	13.1
48	12	12
50	10.9	10.9
52	10.4	10.4
54	9.3	9.3
56	8.5	8.5
58		